



UFH SERIES

Ultra Flow Cartridge Filter Housings

- Horizontal Orientation
- Flow rates up to 9,000 GPM
- ASME Design/Industrial Design

Ideal for a broad range of applications, the UFH Series offers maximum flow rates in a smaller footprint.



SUITABLE USES



Air & Gas



Desalination



Coolant



Water



Electronics



Coatings



Oil & Gas



Chemical



Pulp & Paper



Power



Marine



Equipment

COMPATIBLE MEDIA Fil-Trek Ultra Flow Series

DESIGN PRESSURE 150 PSIG (10.3bar) @ 400°F (204.4°C)

AVAILABLE MATERIALS Vessels available in carbon or stainless steel 304 or 316. Also available in LDX2101, C276, AL6XN, RA2205 & Monel 400 and Titanium.
NSF/ANSI Standard 61 available for SS304 and SS316.

ADDITIONAL FEATURES Proprietary tool-less removable baskets offer easy element change-out.



Certified to
NSF/ANSI 61

Custom sizes, configurations, materials of construction and other options may be available. Please contact Fil-Trek

For drawings, flow charts, custom applications and filter cartridge information please visit www.fil-trek.com.

UFH SERIES

Ultra Flow Cartridge Filter Housings Horizontal

- Horizontal Orientation
- Flow rates up to 9,000 GPM
- ASME Design/Industrial Design



HOUSING SPECIFICATIONS

*Indicates standard configuration

Inlet/Outlet	3" Flange -24" Flange
Clean Drain	2" NPT
Vent	½" NPT
Gauges	½" NPT
Certifications	U, UM, CE, NB, CRN

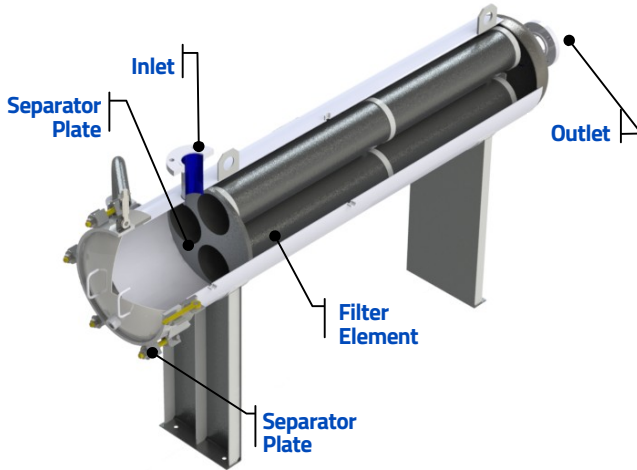

MODEL FLOW RATES

MODEL	# OF FILTERS	FLOW RATE GPM 40"	FLOW RATE GPM 60"	MAX INLET/OUTLET (IN)
UF16	3	525	750	6"
UF18	4	700	1000	8"
UF20	5	875	1250	8"
UF22	7	1225	1750	10"
UF26	9	1575	2250	10"
UF28	10	1750	2500	12"
UF30	12	2100	3000	12"
UF32	14	2450	3500	12"
UF34	15	2625	3750	14"
UF36	19	3325	4750	16"
UF38	20	3500	5000	16"
UF40	22	3850	5500	18"
UF42	23	4025	5750	18"
UF44	28	4900	7000	18"
UF48	32	5600	8000	20"
UF50	36	6300	9000	24"

For maximum efficiency/product life, the flow rates are based on water. Actual Flow rate is dependent on fluid viscosity, cartridge micron rating, contaminant and type of media.

COMPATIBLE FILTERS

UF SERIES FILTERS

Absolute rated, pleated media filters that suit a wide range of applications. Available in micron ratings between 1 and 100.

[Click to view UF Series](#)



Available with materials that are in compliance with NSF/ANSI Standard 61



MATERIAL OF CONSTRUCTION

MATERIAL OF CONSTRUCTION	MAX. OPERATING PRESSURE	MAX. DESIGN TEMP
Carbon Steel	150 PSI (10.3bar)	400°F (204°C)
304 Stainless Steel	150 PSI (10.3bar)	400°F (204°C)
316 Stainless Steel	150 PSI (10.3bar)	400°F (204°C)



55 Stafford Court, Cambridge, ON N1T 1B3 P (519) 623-7448 F (519) 623-8807

For more information, e-mail: info@fil-trek.com or visit Fil-Trek.com

UFH SERIES

Ultra Flow Cartridge Filter Housings Horizontal

- Horizontal Orientation
- Flow rates up to 9,000 GPM
- ASME Design/Industrial Design



HOUSING OPTIONS

*Indicates standard configuration

Configuration Options (-) E - Top In/End Out*
C - Side In/End Out

Finish Options (-) - External paint "National Blue" (std for CS)
(-) - Bead Blast (std for SS304 and SS316)
EP1 - Electro polish Inside/Outside
EP2 - Inside only
EP3 - Outside only
PP - Passivation

O-Ring Options (-) - Buna-N*
ED - EPDM
VI - Viton
SI - Silicone
TF - Teflon

Closure Assembly Options (-) Mechanical Davit (std for UFH12 and larger)*
(-) Hydraulic Davit (std for UFH40 and larger)*
K3 - Hydraulic Jack Davit Side
K4 - Hydraulic Jack Davit Top
*See page 5-6 for other closure options

Accessories Direct Reading Gauge
DP Gauge
Safety Relief Valves
Vent Valves
Drain Valves
Air Eliminator

Other Options Stainless Steel bolting
Passivation
Electropolished, Inside/Out
Skid Mounting
Duplexing

MODEL DIMENSIONAL DETAILS

MODEL	WEIGHT	A	B	C	D	E	F
UFH16	425	16½"	50"	36"	56"	70"	74"
UFH18	500	18½"	51"	36"	56"	70"	74"
UFH20	600	20½"	51"	36"	56"	73"	77"
UFH22	900	22½"	52"	36"	62"	81"	85"
UFH26	1100	26½"	57"	36"	62"	85"	89"
UFH28	1400	28½"	59"	36"	64"	88"	92"
UFH30	1600	30½"	58"	36"	64"	88"	92"
UFH32	1750	32½"	58"	36"	64"	88"	92"
UFH34	1850	34½"	60"	36"	68"	92"	96"
UFH36	2100	36½"	62"	36"	72"	94"	98"
UFH38	2450	38½"	62"	36"	72"	101"	105"
UFH40	2700	40½"	62"	36"	74"	103"	107"
UFH42	2900	42½"	62"	36"	74"	103"	107"
UFH44	3300	44½"	72"	42"	74"	102"	106"
UFH48	4100	48¾"	77"	42"	76"	114"	118"
UFH50	4500	50¾"	82"	42"	76"	114"	118"

Dimensions above are for 40" elements, style E and are approximate. Contact factory for weights and dimensions for all other model configurations.

CHART LEGEND

- A OUTSIDE DIAMETER
- B FLOOR TO INLET
- C FLOOR TO OUTLET
- D FACE TO FACE
- E OVERALL LENGTH
- F OVERALL HEIGHT

E Top In/End Out*

Side View

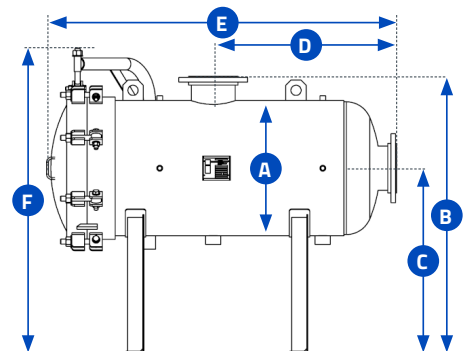

UFH SERIES

Ultra Flow Cartridge Filter Housings Horizontal

- Horizontal Orientation
- Flow rates up to 9,000 GPM
- ASME Design/Industrial Design



FLOW CHART

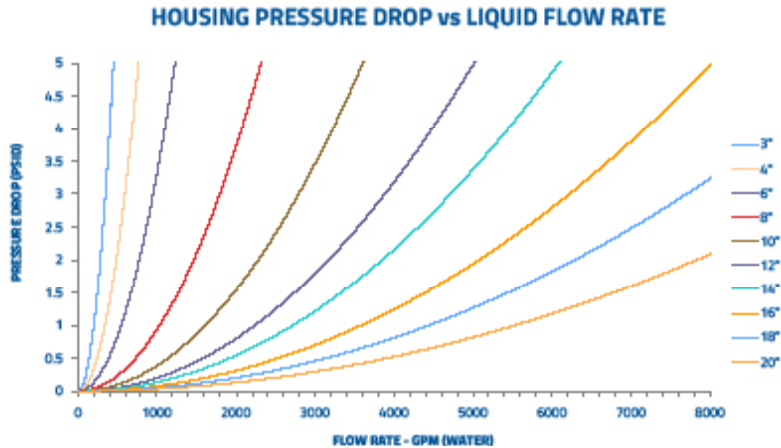

ADDITIONAL MODEL CONFIGURATIONS

E Top In/End Out*

Side View

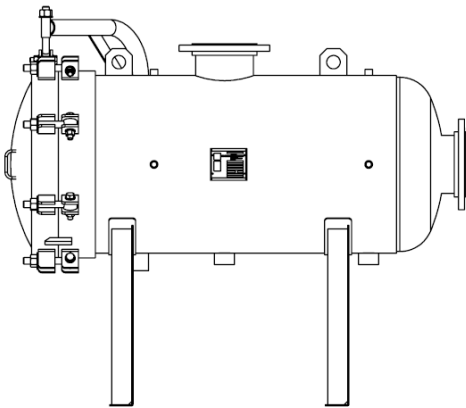

C Side In/End Out

Side View

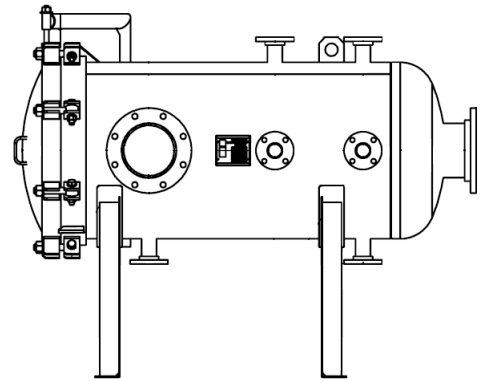

PRODUCT NOMENCLATURE

S6	UFH	16	003	60	6F	150	
MATERIAL	MODEL	HOUSING DIAMETER	#OF CARTRIDGES	LENGTH	CONNECTION TYPE	DESIGN PRESSURE	
(-) – CARBON S4 – SS304 S6 – SS316	UFH - ASME CODE EUFH - NON ASME	See Table	See Table	20 40 60	See Table	150 300	See Housing Options for more options



55 Stafford Court, Cambridge, ON N1T 1B3 P (519) 623-7448 F (519) 623-8807

For more information, e-mail: info@fil-trek.com or visit Fil-Trek.com

UFH SERIES

Ultra Flow Cartridge Filter Housings Horizontal

- Horizontal Orientation
- Flow rates up to 9,000 GPM
- ASME Design/Industrial Design



CLOSURE AND QUICK OPENING COVER OPTIONS

Fil-Trek designs and fabricates a variety of closure and quick opening cover options to accommodate strict applications and requirements. All materials of construction are in accordance with ASME specifications and manufacturing complies with the applicable rules of the ASME Code for Pressure Piping and with the ASME Boiler and Pressure Vessel Code.

HINGED COVER

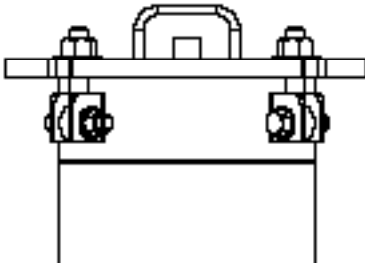

The most economical quick opening closure offered for fabricated strainers with nominal pressure applications. The swing bolt hinged cover uses an O-ring to seal. Easy to open by quickly and easily by loosening the swing bolts until they clear the holding lugs and swinging the head open on its hinge.

MECHANICAL DAVIT ASSEMBLY

Our mechanical davit assembly makes it easy for the operator to open and swing the cover away to facilitate basket or screen removal for cleaning. It is used primarily for larger strainers where cover removal is difficult and heavy. This is the most inexpensive alternative to quick release covers, especially when operating conditions require a bolted cover. Available for swing bolt and ANSI closures.

**Hydraulic davit head lift also available.

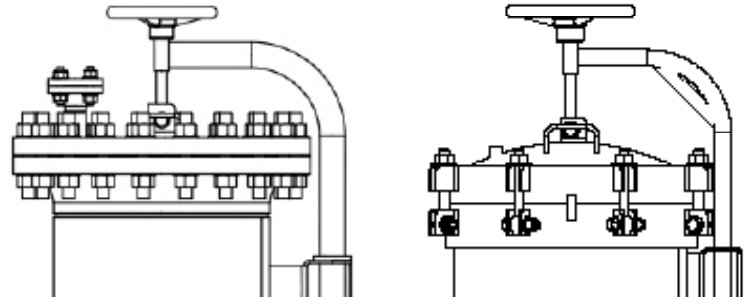

UFH SERIES

Ultra Flow Cartridge Filter Housings Horizontal

- Horizontal Orientation
- Flow rates up to 9,000 GPM
- ASME Design/Industrial Design



THREADED HINGED COVER

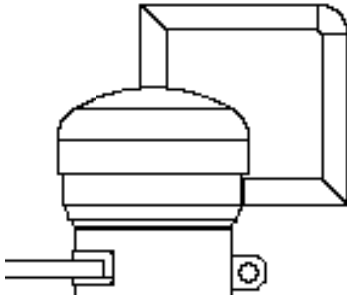

The quick open threaded hinged closure uses a cap fastened to a hub and is welded to the strainer body. The female cap is threaded onto the male hub using O-rings to seal. The O-ring prevents corrosion of the closure threads and provides a long, trouble free service. The threaded cover can be used for both nominal and high pressure applications. Available in both vertical and horizontal configurations.

YOKE CLOSURE

The Yoke hinged cover is a true ANSI rated closure and uses an O-ring seal. Used primarily on high pressure applications, it is available for 150#, 300#, 600#, 900# and 1500# ANSI ratings with a wide range of operating aids, ranging from a single lever chain and sprocket drive to completely automated.

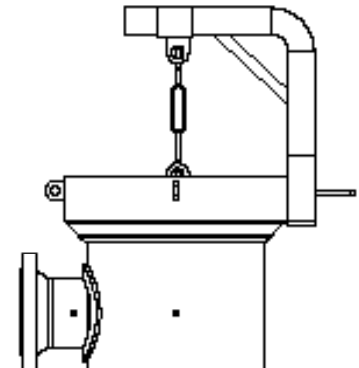

CLOSURE COMPARISON

	COVER TYPE			
	HINGED COVER	MECHANICAL DAVIT	THREADED COVER	YOKE CLOSURE
COST	Low	Moderate	High	High
QUICK OPENING ABILITY	Good	Fair	Best	Best
LOW PRESSURE APPLICATIONS	X	X	-	-
NOMINAL PRESSURE APPLICATIONS	X	X	X	X
HIGH PRESSURE APPLICATIONS	-	X	X	X