



Temporary Strainers

Cone | Basket | Plate

- Excellent for pipeline start up or minimal solid loading
- 100% to 300% open area range (OAR)
- Sizing from 3/4" to 36"

Temporary strainers offer excellent low cost protection for costly filtration equipment, valves and other mechanical equipment



SUITABLE USES



Air & Gas



Desalination



Coolant



Water



Electronics



Coatings



Oil & Gas



Chemical



Pulp & Paper



Power



Marine



Equipment

RATINGS

- Class 150
- Class 300
- Class 600
- Class 900
- Class 1500
- Class 2500

DESIGN PRESSURE

Up to 3700 @ 800° F (427° C)

AVAILABLE MATERIALS

Carbon or Stainless Steel 304 or 316, LDX2101, C276, AL6XN, 2205, 2507 & Monel 400, Titanium and other materials.

ADDITIONAL FEATURES

Designed for bidirectional flow paths.
Suitable for both vertical and horizontal pipelines.
CRN registration available.

Custom sizes, configurations, materials of construction and other options may be available. Please contact Fil-Trek

For more information, e-mail: info@fil-trek.com or visit Fil-Trek.com

Temporary Strainers

Cone | Basket | Plate

- Great for pipeline start up
- 100% to 300% OAR
- Sizing from 3/4" to 36"

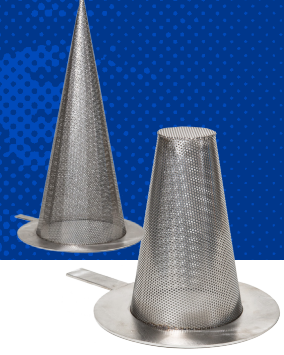

STRAINER SPECIFICATIONS

Configuration	97A - Cone design 97B - Basket design 97C - Plate design	
Inlet/Outlet	2" TO 36" <i>Larger sizes available, contact Fil-Trek</i>	
Open Area Ratio (OAR)	100% 150% 200% 300% <i>Custom OAR available</i>	
Handles	All temporary strainers are designed with handles. Typically 3" long x 1" wide. <i>Custom sizing available.</i>	
Basket/Mesh Options	PERF OPTIONS	MESH OPTIONS
<i>(See Screen Openings chart for more options)</i>	1/8"*	10
	3/16"	20
	1/4"	30
	3/8"	40
	1/2"	50
	5/8"	60
	3/4"	80
	7/8"	100
	1"	120

PRESSURE & TEMPERATURE DESIGNATION

DESIGNATION	MOC	PSI	TEMP (°F)	ANSI RATING
PT1	CS	280	100	ANSI 150
	SS304/SS316	270		
PT2	CS	195	400	ANSI 150
	SS304/SS316	185		
PT3	CS	735	100	ANSI 300
	SS304/SS316	715		
PT4	CS	630	400	ANSI 300
	SS304/SS316	490		
PT5	CS	1475	100	ANSI 600
	SS304/SS316	1435		
PT6	CS	1260	400	ANSI 600
	SS304/SS316	990		
PT7	CS	2215	100	ANSI 900
	SS304/SS316	2155		
PT8	CS	1895	400	ANSI 900
	SS304/SS316	1485		
PT9	CS	3700	100	ANSI 1500
	SS304/SS316	3595		
PT10	CS	3165	400	ANSI 1500
	SS304/SS316	2480		

*Table above based on ANSI flange ratings. Fil-Trek will design based on application pressure and temperature requirements.

**Max temperature may be limited to gasket material.

PRODUCT NOMENCLATURE

S4	97B	6	100	PT2	-
MOC	MODEL	FLANGE SIZE	OAR %	PRESSURE CLASS	ADDITIONAL OPTIONS
<ul style="list-style-type: none"> (-) CARBON STEEL S4 - SS304 S6 - SS316 	<ul style="list-style-type: none"> 97A - Cone design 97B - Basket design 97C - Plate design 	<ul style="list-style-type: none"> See tables on proceeding pages for inlet/outlet sizing 	<ul style="list-style-type: none"> 100 - 100% OAR 150 - 150% OAR 200 - 200% OAR 300 - 300% OAR --- - Custom 	<ul style="list-style-type: none"> See Pressure & Temperature Designation table 	<ul style="list-style-type: none"> See options above for: Basket Perf/Mesh options

*For sizing for your application, please contact factory



55 Stafford Court, Cambridge, ON N1T 1B3 P (519) 623-7448 F (519) 623-8807

For more information, e-mail: info@fil-trek.com or visit Fil-Trek.com

Temporary Strainers

Cone | Basket | Plate

- Great for pipeline start up
- 100% to 300% OAR
- Sizing from 3/4" to 36"

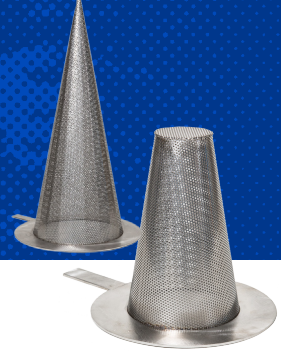

MODEL DIMENSIONAL DETAILS

97A (Cone Design)

FLG SIZE	A					B	C	D				E
	150#	300#	600#	900#	1500#			100%	150%	200%	300%	
3/4"	2.13	C/F	2.5	2.63	2.63	0.63	11	C/F	C/F	C/F	C/F	N/A
1"	2.5	C/F	2.75	3	3	0.75	11	C/F	C/F	C/F	C/F	N/A
1 1/2"	3.25	3.63	3.63	3.75	3.75	1.25	11	3.5	4.5	6	9	N/A
2"	4	4.25	4.25	5.5	5.5	1.75	11	4	6	8	11	N/A
2 1/2"	4.75	5	5	6.38	6.38	2.25	11	4	6	8	11	N/A
3"	5.25	5.75	5.75	6.5	6.75	2.75	11	5	7	9	13	N/A
4"	6.75	7	7.5	8	8.13	3.75	11	8	10	12	18	N/A
5"	7.63	8.38	9.38	9.63	9.88	4.63	11	8	11	14	22	N/A
6"	8.63	9.75	10.38	11.25	11	5.38	11	9	13	18	25	N/A
8"	10.88	12	12.5	14	13.75	7.38	11	12	17	23	33	N/A
10"	13.25	14.13	15.63	17	17	9.38	11	14	21	28	41	N/A
12"	16	16.5	17.88	19.5	20.38	11	11	16	25	34	49	N/A
14"	17.38	19	19	20.38	22.63	12.25	11	18	27	36	53	N/A
16"	20.13	21.13	21.88	22.5	C/F	14	11	21	31	40	61	N/A
18"	21.25	23.38	23.75	25	C/F	15.75	11	24	35	46	68	N/A
20"	23.5	25.63	26.63	C/F	C/F	17.5	11	26	38	51	76	N/A
24"	27.88	30.38	30.88	C/F	C/F	21.25	11	31	45	61	90	N/A

Available in sizes larger than 24". Specifications listed above are for reference only. All quotes are complete with certified drawing which indicate accurate dimensions and weight.

CHART LEGEND

- A** Outside Diameter
- B** Inside Diameter
- C** Gauge Thickness
- D** Length
- E** Bottom Diameter (if applicable)

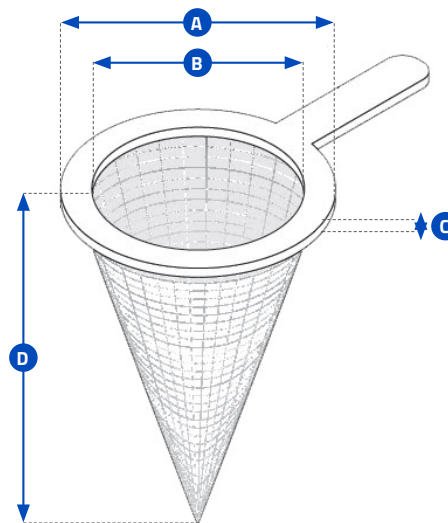

Temporary Strainers

Cone | Basket | Plate

- Great for pipeline start up
- 100% to 300% OAR
- Sizing from 3/4" to 36"

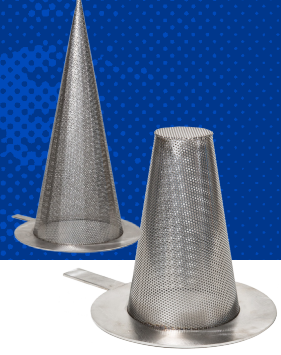

MODEL DIMENSIONAL DETAILS

97B (Basket Design)

FLG SIZE	A					B	C	D				E
	150#	300#	600#	900#	1500#			100%	150%	200%	300%	
3/4"	2.13	C/F	2.5	2.63	2.63	0.63	11	C/F	C/F	C/F	C/F	0.38
1"	2.5	C/F	2.75	3	3	0.75	11	C/F	C/F	C/F	C/F	0.5
1 1/2"	3.25	3.63	3.63	3.75	3.75	1.25	11	2	2.5	3.5	5	0.75
2"	4	4.25	4.25	5.5	5.5	1.75	11	2.5	3	4	6	1
2 1/2"	4.75	5	5	6.38	6.38	2.25	11	2.5	3	4.5	6	1.25
3"	5.25	5.75	5.75	6.5	6.75	2.75	11	3	4.5	6	8	1.5
4"	6.75	7	7.5	8	8.13	3.75	11	4	5	7	11	2
5"	7.63	8.38	9.38	9.63	9.88	4.63	11	4.5	7	9	14	2.5
6"	8.63	9.75	10.38	11.25	11	5.38	11	5.5	8	11	17	3
8"	10.88	12	12.5	14	13.75	7.38	11	7	11	14	21	4
10"	13.25	14.13	15.63	17	17	9.38	11	8	13	17	26	5
12"	16	16.5	17.88	19.5	20.38	11	11	10	15	20	31	6
14"	17.38	19	19	20.38	22.63	12.25	11	10	16	22	33	7
16"	20.13	21.13	21.88	22.5	C/F	14	11	12	19	24	37	8
18"	21.25	23.38	23.75	25	C/F	15.75	11	14	21	27	41	9
20"	23.5	25.63	26.63	C/F	C/F	17.5	11	16	24	31	48	10
24"	27.88	30.38	30.88	C/F	C/F	21.25	11	18	28	37	57	12

Available in sizes larger than 24". Specifications listed above are for reference only. All quotes are complete with certified drawing which indicate accurate dimensions and weight.

CHART LEGEND

- A** Outside Diameter
- B** Inside Diameter
- C** Gauge Thickness
- D** Length
- E** Bottom Diameter (if applicable)

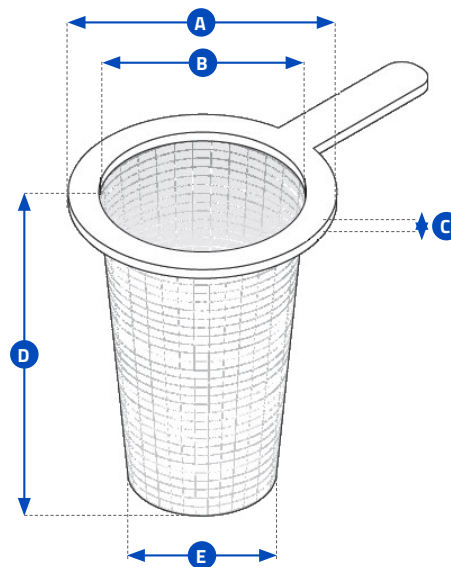

Temporary Strainers

Cone | Basket | Plate

- Great for pipeline start up
- 100% to 300% OAR
- Sizing from 3/4" to 36"

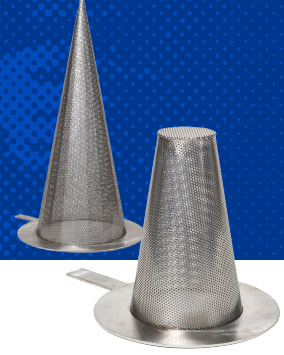

MODEL DIMENSIONAL DETAILS

97C (Plate Design)

FLG SIZE	A					B	C
	150#	300#	600#	900#	1500#		
3/4"	2.13	C/F	2.5	2.63	2.63	0.63	11
1"	2.5	C/F	2.75	3	3	0.75	11
1 1/2"	3.25	3.63	3.63	3.75	3.75	1.25	11
2"	4	4.25	4.25	5.5	5.5	1.75	11
2 1/2"	4.75	5	5	6.38	6.38	2.25	11
3"	5.25	5.75	5.75	6.5	6.75	2.75	11
4"	6.75	7	7.5	8	8.13	3.75	11
5"	7.63	8.38	9.38	9.63	9.88	4.63	11
6"	8.63	9.75	10.38	11.25	11	5.38	11
8"	10.88	12	12.5	14	13.75	7.38	11
10"	13.25	14.13	15.63	17	17	9.38	11
12"	16	16.5	17.88	19.5	20.38	11	11
14"	17.38	19	19	20.38	22.63	12.25	11
16"	20.13	21.13	21.88	22.5	C/F	14	11
18"	21.25	23.38	23.75	25	C/F	15.75	11
20"	23.5	25.63	26.63	C/F	C/F	17.5	11
24"	27.88	30.38	30.88	C/F	C/F	21.25	11

Available in sizes larger than 24". Specifications listed above are for reference only. All quotes are complete with certified drawing which indicate accurate dimensions and weight.

CHART LEGEND

- A** Outside Diameter
- B** Inside Diameter
- C** Gauge Thickness

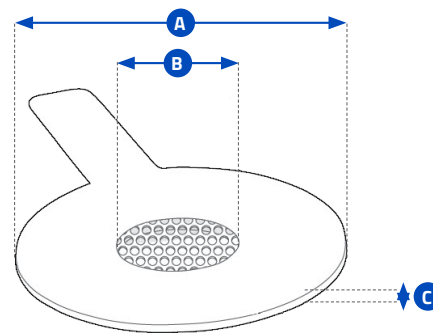

Temporary Strainers

Cone | Basket | Plate

- Great for pipeline start up
- 100% to 300% OAR
- Sizing from 3/4" to 36"

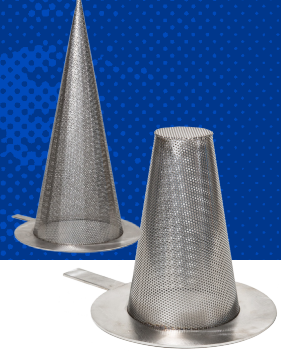

SCREEN/BASKET DESIGN CHECKLIST

97A Cone Design

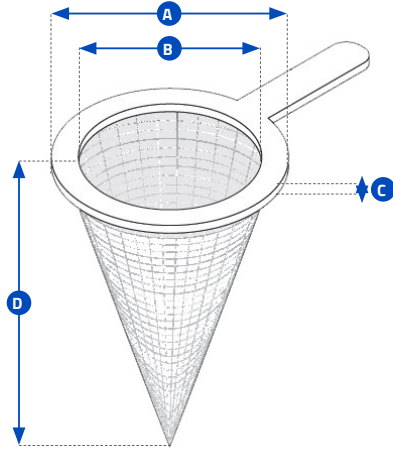

97B Basket Design

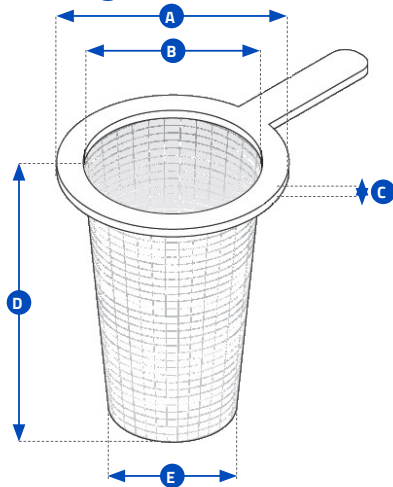

97C Plate Design

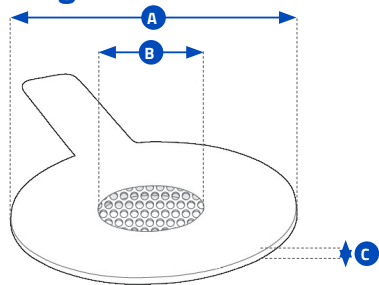

Performance Requirements

Req. Level of Filtration

Material of Construction

Min. Specified Burst Pressure

Flow Direction

Dimensional Requirements

Design Style (Cone, Basket or Plate)

A* Outside Diameter

B* Inside Diameter

C* Gauge Thickness

D Overall Length

E Bottom Outside Diameter

(For basket style only)

Desired Handle Size

**Required for plate design.*

Additional Notes

Temporary Strainers

Cone | Basket | Plate

- Great for pipeline start up
- 100% to 300% OAR
- Sizing from 3/4" to 36"

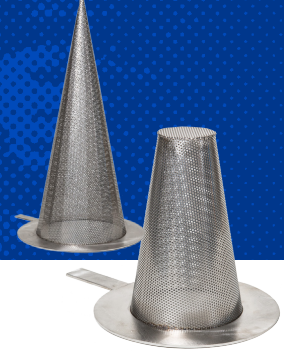

SCREEN OPENINGS

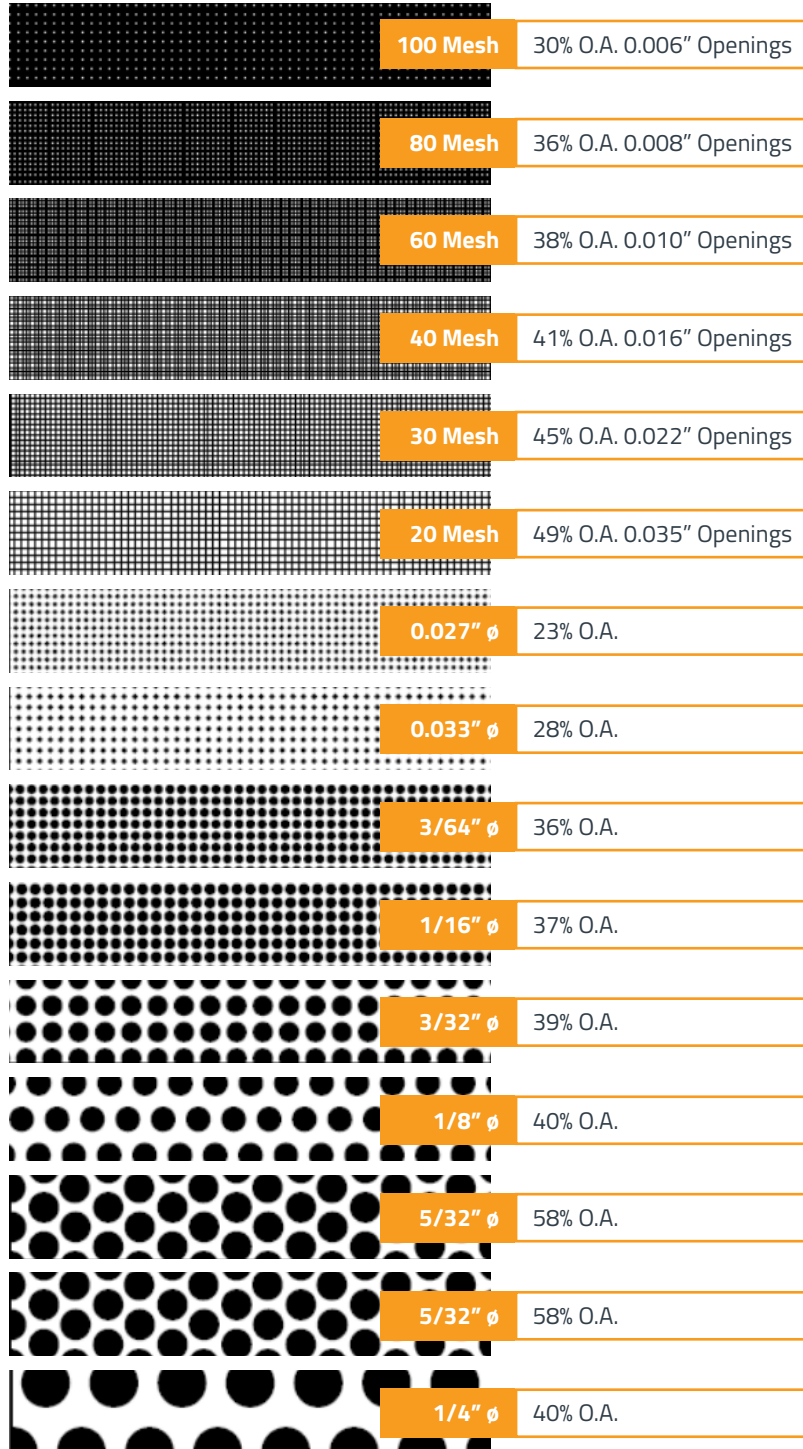

FACTORS TO CONSIDER

1 Purpose

If the strainer is being used for protection rather than direct filtration, standard screens will suffice in most applications.

2 Service

With services that require extremely sturdy screens, such as high pressure/temperature applications or services with high viscosities, perforated screens without mesh liners are recommended. If a mesh liner is required to obtain a certain level of filtration, then a trapped perf/mesh/perf combination is recommended.

3 Filtration Level

When choosing a perf. or a mesh/perf. combination, attention should be given to ensure overstraining does not occur. As a general rule, the specified level of filtration should be no smaller than half the size of the particle to be removed. If too fine a filtration is specified, the pressure drop through the strainer will increase very rapidly, possibly causing damage to the screen.

Screen openings other than those shown above are readily available. Various mesh sizes as fine as 5 micron and perforated plate as coarse as 1/2" Dia. are in inventory.

Screens are available in a wide range of materials. Screens of carbon steel, stainless steel (304, 316), alloy 20, monel 400, hastelloy C and titanium grade 2 are in inventory.

Custom manufactured screens are available upon request. Please consult factory.

Temporary Strainers

Cone | Basket | Plate

- Great for pipeline start up
- 100% to 300% OAR
- Sizing from 3/4" to 36"

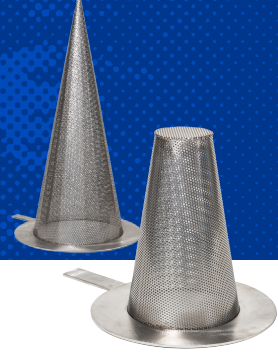

PRESSURE DROP | LIQUIDS

Temporary Strainers | 3/4" to 5"

Figure 5

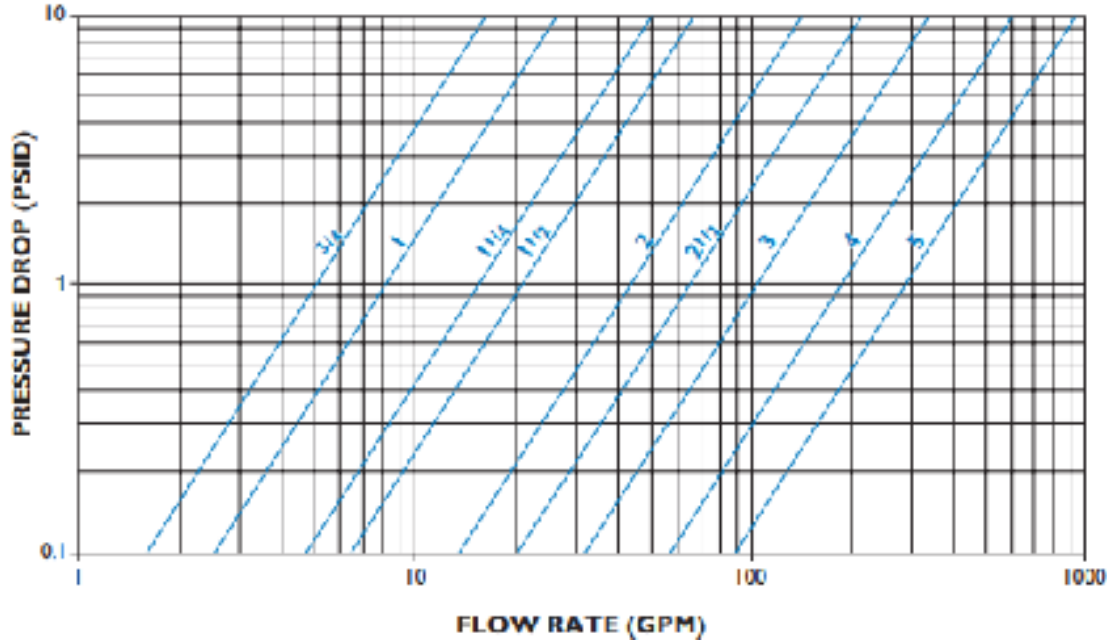

Temporary Strainers | 6" to 48"

Figure 6

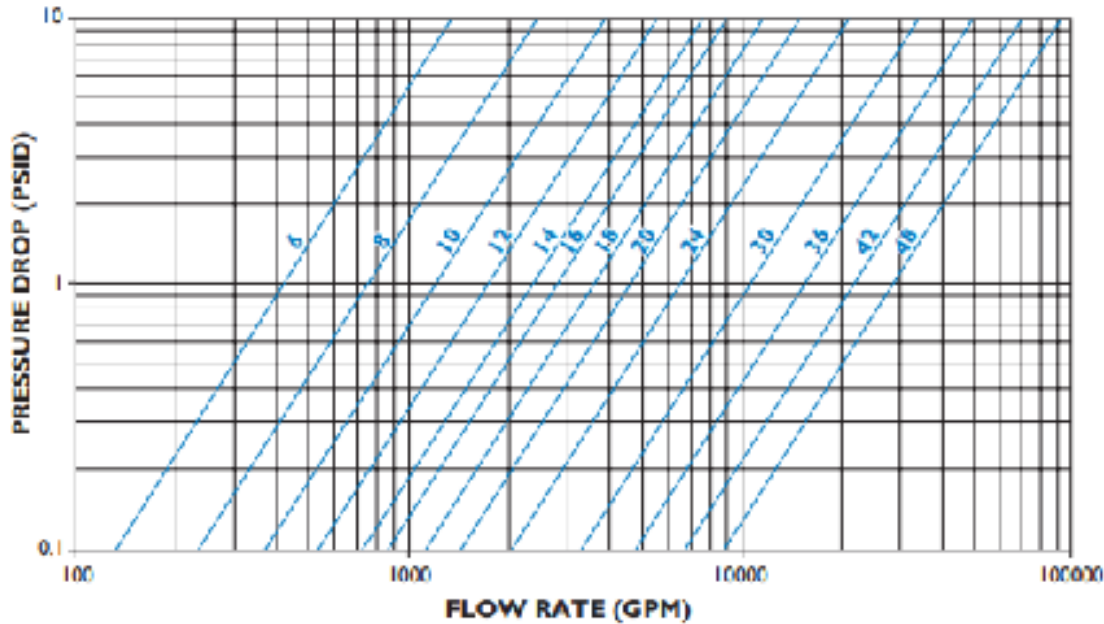

Notes:

Pressure drop curves are based on water flow with standard screens.

See Chart # 1 for correction factors to be used with other fluids and/or screen openings.



55 Stafford Court, Cambridge, ON N1T 1B3 P (519) 623-7448 F (519) 623-8807

For more information, e-mail: info@fil-trek.com or visit Fil-Trek.com

Temporary Strainers

Cone | Basket | Plate

- Great for pipeline start up
- 100% to 300% OAR
- Sizing from 3/4" to 36"

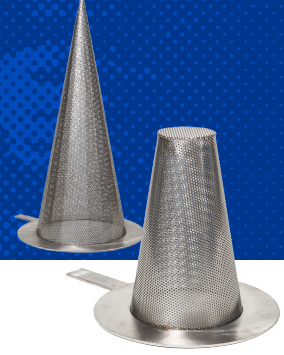

SCREEN CORRECTION FACTOR CHART

Non-Standard and Mesh Lined Screens

Chart # 1

SIZE RANGE	PERF. PLATE % SCREEN MATERIAL OPEN AREA					MESH LINED SCREENS % SCREEN MATERIAL OPENING AREA		
	60%	50%	40%	30%	20%	50%	40%	30%
1/4" to 1 1/2"	0.45	0.55	0.70	1.00	1.15	1.05	1.05	1.20
2" to 48"	0.65	0.80	1.00	1.40	2.15	1.05	1.05	1.20

BASKET STRAINER EXAMPLE

Strainer Size: 10"
Screen Size: 100 Mesh, 1/8" Perf
Flow Rate: 3000 GPM
Service: Water
Specific Gravity: 1
Viscosity: 100 cP

How To Calculate:

- Use Figure 1 to get the pressure drop of the screen.
- Refer to the Screen Opening chart to determine the % Open Area of the mesh/screen size being used.
- Using the chart above, find the correction factor to be used.
- Multiply the PSID by the correction factor to determine the total pressure drop.

Example:

RESULTS
2.0
30%
1.20
2.4
2.0 x 1.2 = 2.4 PSID clean

VISCOSITY & DENSITY CORRECTION FACTOR CHART

Chart # 2

SIZE RANGE	COMPONENT FACTOR (CF)
3/4" to 1 1/2"	0.25
2" to 48"	0.35

Chart # 3

VISCOSITY (cP)	BODY LOSS FACTOR (BF)	SCREEN LOSS FACTOR			
		PERF ONLY (PF)	20 MESH (MF)	30 to 40 MESH (MF)	60 to 300 MESH (MF)
10	1.0	1.15	1.20	1.40	1.50
25	1.2	1.25	2.00	2.20	2.50
100	1.6	1.40	3.00	4.00	6.50
200	2.2	1.50	4.50	7.00	11.50
500	4.4	1.60	10.00	15.00	25.00
1000	8.0	1.70	15.00	30.00	50.00
2000	15.0	1.90	30.00	60.00	100.00

How To Calculate:

- Use the pressure drop (P1) through the strainer with water flow and standard or mesh screens from Chart # 1.
- Multiply P1 by the specific gravity of the fluid actually flowing through the strainer to get P2.
- Using Chart # 2 above, multiply P2 by the correct component factor to get P3.
- Subtract P3 from P2 to equal P4.
- Multiply P3 by the appropriate Body Loss factor from Chart # 3 above to get P5.
- Multiply P4 by the appropriate Screen Loss factor from Chart # 3 above to get P6.
- Total pressure drop will be P5 + P6 = P7.

RESULTS
2.4
2.4
0.84
1.56
1.34
10.14
Total Pressure Drop = 11.48 PSID clean

Temporary Strainers

Cone | Basket | Plate

- Great for pipeline start up
- 100% to 300% OAR
- Sizing from 3/4" to 36"

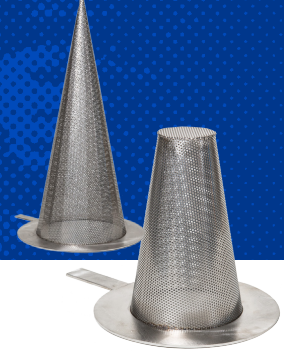

CORRECTION FACTORS

For Clogged Screens

Chart # 4

% CLOGGED	RATIO OF FREE SCREEN AREA TO PIPE AREA						
	10:1	8:1	6:1	4:1	3:1	2:1	1:1
10%	-	-	-	-	-	-	3.15
20%	-	-	-	-	-	1.15	3.90
30%	-	-	-	-	-	1.40	5.00
40%	-	-	-	-	-	1.80	6.65
50%	-	-	-	-	1.25	2.50	9.45
60%	-	-	-	1.15	1.80	3.70	14.50
70%	-	-	-	1.75	2.95	6.4	26.00
80%	-	1.10	1.75	3.60	6.25	14.00	58.00
90%	2.30	3.45	6.00	13.50	24.00	55.00	-

NOTES:

- See Figures 7 to 10 for the ratio of free area to pipe area for Fil-Trek strainers equipped with standard screens.
- For screens other than Fil-Trek standard, use the following formula to calculate the ratio free area to pipe area:

$$R = \frac{Ag \times OA}{100Ap}$$

where;

- R = Ratio free area to pipe area
- Ag = Gross screen area, sq. in. (see Figures 7 to 10)
- OA = Open area of screen media, % (Screen Opening chart, i.e. 1/8" perf = 40%)
- Ap = Nominal area of pipe fitting, sq. in. (see Figures 7 to 10)

STANDARD SCREEN EXAMPLE	How To Calculate:	RESULTS
T Strainer Size: 8" Screen Size: 5/32" Perf Flow Rate: 1000 GPM Service: Water % Clogged: 60%	1) Find the pressure drop using Figure 3. 2) Reference the ratio of free area to pipe area using Figure 9. 3) Using Chart # 4 above, find the correction factor based on the % clogged. 4) Calculate the total pressure drop by multiplying the pressure drop from step 1 with the correction factor from step 3.	0.9 1.3:1 (round down to 1:1) 3.9 0.9 x 3.9 = 3.51 PSID

NON STANDARD SCREEN EXAMPLE	How To Calculate:	RESULTS
T Strainer Size: 8" Screen Size: 1/8" Perf Flow Rate: 1000 GPM Service: Water % Clogged: 20%	1) Find the pressure drop on page using Figure 3 with a standard screen size. 2) Using the Screen Correction chart to determine the % of open area (OA) of 5/32" perf. 3) See Chart # 1 to find the correction factor for 5/32" perf (round up). 4) Multiply step 1 by the pressure drop from step 3. 5) SINCE a non-standard screen is being used, use the formula above to calculate the Ratio free area to pipe area (Ag = 167, OA = 58%, Ap = 50.3). 6) Using the result from step 5, check Chart # 4 to find the correction factor. 7) Multiply results from step 4 and step 6 to get the pressure drop when clogged.	0.9 58% 0.65 0.9 x 0.65 = 0.59 PSID 1.9:1 (round up to 2:1) 3.7 0.59 x 3.7 = 2.2 PSID



55 Stafford Court, Cambridge, ON N1T 1B3 P (519) 623-7448 F (519) 623-8807

For more information, e-mail: info@fil-trek.com or visit Fil-Trek.com

Temporary Strainers

Cone | Basket | Plate

- Great for pipeline start up
- 100% to 300% OAR
- Sizing from 3/4" to 36"

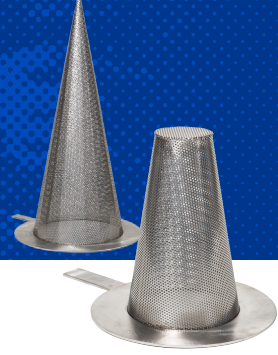

SCREEN BURST PRESSURE

Temporary Basket Strainers

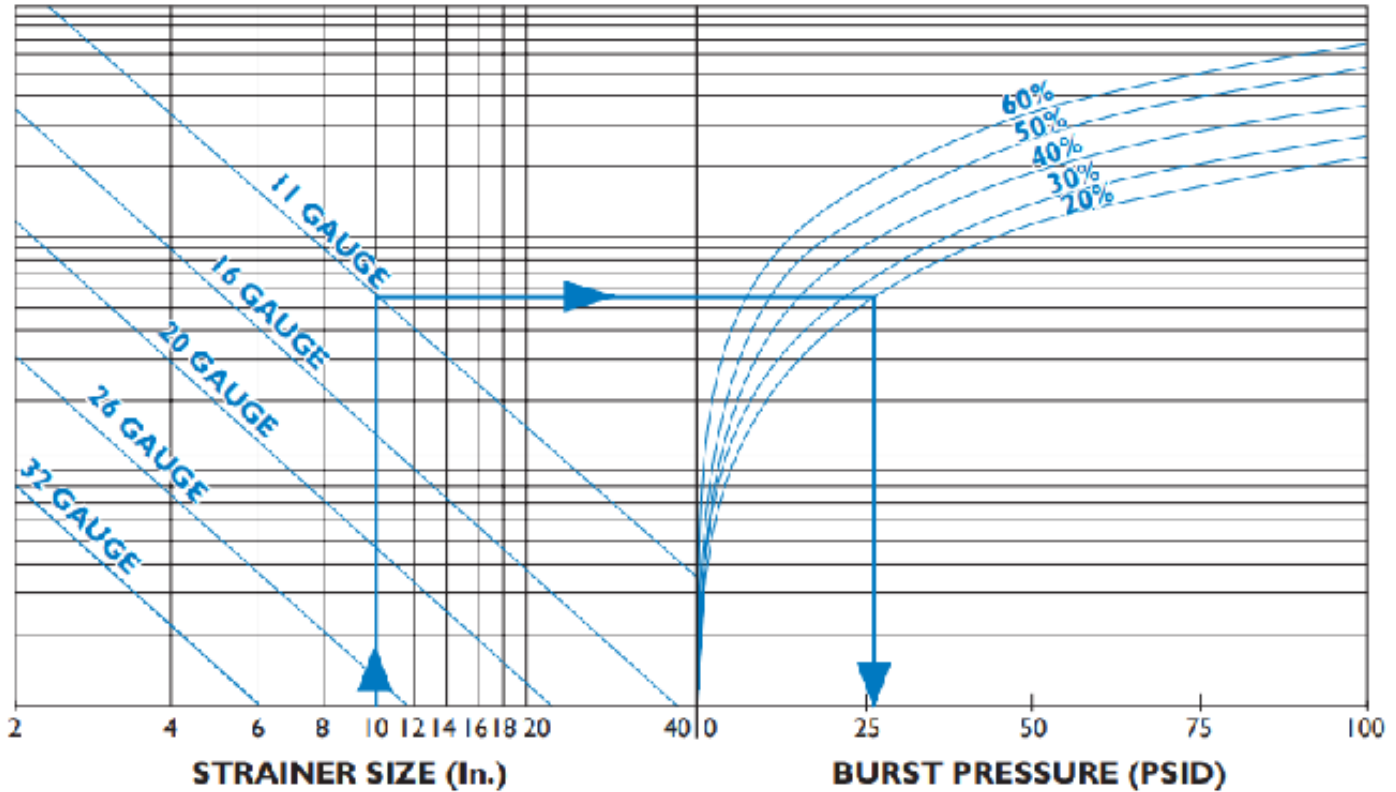

NOTES:

- The above chart is to be used for strainers manufactured from perforated plate and is based on the formula below
- The above chart is based on standard dimensions. Higher burst pressure ratings are available. Please contact factory.
- The above chart is based on a screen material of stainless steel. No safety factor is incorporated. It is the responsibility of the user to determine an acceptable safety factor.
- See the Screen Openings chart for % Open Area's of standard perforated plate.

$$t = d \sqrt{\frac{0.3P}{S}}$$

t = Thickness of perforated plate, in.
d = Dimension B (see strainer sizing), in.
P = Burst Pressure, psi
S = Reduced allowable stress, psi

EXAMPLE

Strainer Size: 10"
Basket Type: 11 gauge
Screen Mat'l Open Area: 20%

How To Calculate:

- Locate Strainer size.
- Follow vertical line to gauge thickness.
- Follow horizontal line to required perforation open area.
- Follow vertical line downward to read burst pressure.
- Burst pressure equals **27 psid**.

Temporary Strainers

Cone | Basket | Plate

- Great for pipeline start up
- 100% to 300% OAR
- Sizing from 3/4" to 36"

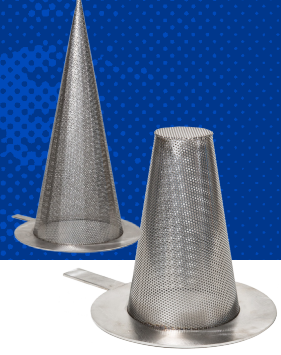

SCREEN BURST PRESSURE

Conical Strainers

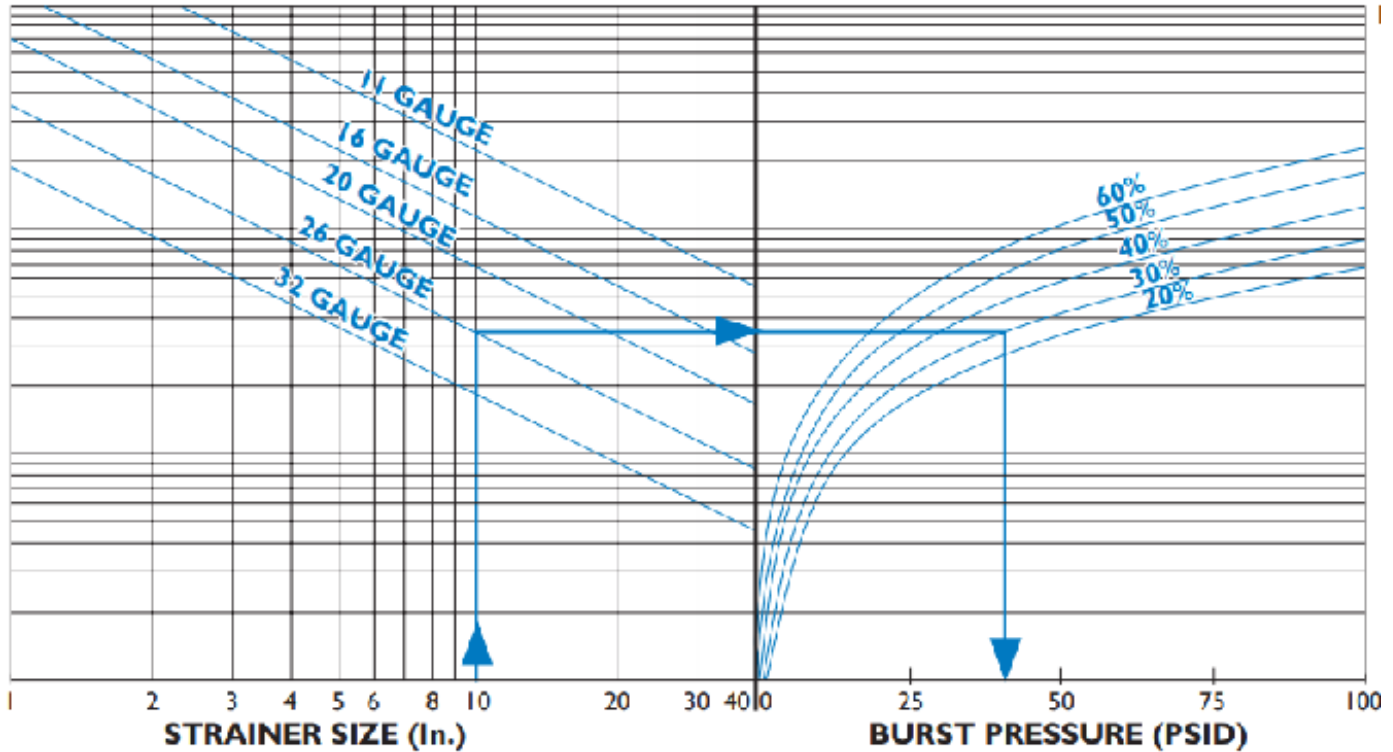

NOTES:

- The above chart is to be used for strainers manufactured from perforated plate and is based on the formula below
- The above chart is based on standard dimensions. Higher burst pressure ratings are available. Please contact factory.
- The above chart is based on a screen material of stainless steel. No safety factor is incorporated. It is the responsibility of the user to determine an acceptable safety factor.
- See the Screen Openings chart for % Open Area's of standard perforated plate.

$$P = \frac{2St \cos \alpha}{D + 1.2t \cos \alpha}$$

- t = Thickness of perforated plate, in.
- d = Dimension B (see strainer sizing), in.
- P = Burst Pressure, psi
- S = Reduced allowable stress, psi
- α = 15 degree

EXAMPLE

- Strainer Size: 10"
- Basket Type: 26 gauge
- Screen Mat'l Open Area: 30%

How To Calculate:

- Locate Strainer size.
- Follow vertical line to gauge thickness.
- Follow horizontal line to required perforation open area.
- Follow vertical line downward to read burst pressure.
- Burst pressure equals **41 psid**.



55 Stafford Court, Cambridge, ON N1T 1B3 P (519) 623-7448 F (519) 623-8807

For more information, e-mail: info@fil-trek.com or visit Fil-Trek.com

Temporary Strainers

Cone | Basket | Plate

- Great for pipeline start up
- 100% to 300% OAR
- Sizing from 3/4" to 36"

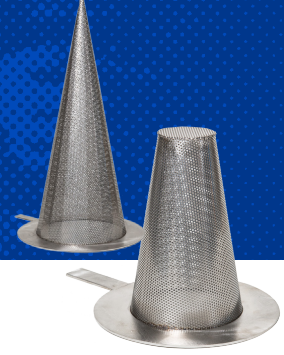

INSTALLATION AND MAINTENANCE INSTRUCTIONS

Strainer installation instructions

- Ensure all machined surfaces are free of defects and that the inside of the strainer is free of foreign objects.
- For horizontal and vertical pipelines, the strainer should be installed so that the blow-down drain connection is pointed downward.
- For flanged end strainers, the flange bolting should be tightened gradually in a back and forth clockwise motion. Threaded end strainers should use an appropriate sealant.
- Once installed, increase line pressure gradually and check for leakage around joints.
- If the strainer is supplied with a start-up screen, monitor pressure drop carefully.

Screen removal instructions

- Drain piping
- Vent line to relieve pressure.
- Loosen cover and open to access screen.
- Remove, clean and replace screen in original position (Note: In some instances, a high pressure water jet or steam may be required for effective cleaning)
- Inspect cover gasket for damage. If necessary, replace. (Note: If spiral wound gaskets have been used, they must be replaced and can not be used again)
- Tighten cover. The strainer is ready for line startup.

CAUTION SHOULD BE TAKEN DUE TO POSSIBLE EMISSION OF PROCESS MATERIAL FROM PIPING. ALWAYS ENSURE NO LINE PRESSURE EXISTS WHEN OPENING COVER

Maintenance instructions

For maximum efficiency, determine the length of time it takes for the pressure drop to double that in the clean condition. Once the pressure drop reaches an unacceptable value, shut down line and follow the "Screen Removal Instructions" above. A pressure gauge installed before and after the strainer in-line will indicate pressure loss due to clogging and may be used to determine when cleaning is required.

Trouble shooting guides and diagnostic techniques

- After pressurizing, inspect cover and other joints for leakage. Gasket replacement or cover tightening is necessary if leakage occurs.
- If the required filtration is not taking place, ensure the screen is installed in the correct position, that being flush to the screen seating surfaces.

WARNING

This product operates in pipelines or with equipment that carries fluids and/or gasses at elevated temperatures and pressures. Caution should be taken to make sure that this equipment is installed correctly and inspected regularly. Caution should also be taken to protect personnel from fluid or gas leakage.